

# LISST-TAU

## HIGH-PRECISION TRANSMISSOMETER

### Optical Transmisson • Beam Attenuation

LISST-Tau is a high-precision transmissometer for underwater vehicles, profiling packages, CTDs, and other systems. With high-quality optics and a carefully selected LED source, it transmits a collimated beam through the water, and precisely measures the light transmitted through its 15 cm path. Light modulation with synchronous detection rejects ambient light, while oversampling and averaging yield better than 16-bit resolution. LISST-Tau's digital controller applies calibration coefficients, corrects for temperature effects, and transmits data from both digital and analog outputs. Included software provides real-time display of data, and functions for checking and updating pure-water calibrations. LISST-Tau advances the state of the art for in-situ transmissometers.



## FEATURES

- Measures optical transmission and beam attenuation
- Externally powered
- RS-232 and analog real-time outputs
- Ambient light rejection
- Onboard temperature compensation
- Available with green or red LED source (specify upon ordering)

## SPECIFICATIONS (subject to change without notice)

### Parameters Measured

- Optical transmission
- Beam attenuation

### Operating Ranges and Stability

- Operational temperature range: -3 °C to 40 °C
- Storage temperature range: 20 °C to 60 °C
- Beam attenuation range: ~0 m<sup>-1</sup> to 30 m<sup>-1</sup>
- Linearity (concentration): >99 %
  - Short-term stability (1 min standard deviation, typical)
    - Transmission: 0.003 %FS (Green) / 0.005% (Red)
    - Beam attenuation: 0.0002 m<sup>-1</sup> (Green) / 0.0004 m<sup>-1</sup> (Red)
- Long-term stability (6 hr test)
  - Transmission: ~0.003 %FS/hr
  - Beam attenuation: ~0.0002 m<sup>-1</sup>·hr<sup>-1</sup>

### Technology

- Optical path length: 15 cm
- Source wavelength: ~532 nm (green) or ~650 nm (red) LED
- Source spectral bandwidth: <10 nm FWHM
- Acceptance angle (half angle, in water): 1.0 °
- Optical transmission @ 16-bit resolution

### Mechanical and Electrical

- Dimensions [Ø x L]: 5.1 cm x 40.6 cm (2.00" x 16")
- Weight [air / seawater]: 1.140 kg / 0.585 kg (2.5 lbs / 1.3 lbs)
- Depth rating: 2,000 m
- Sampling rate: 1 Hz (default)
- External power input: 7 VDC to 25 VDC
- Current drain @ 12V: 42 mA average during sampling
- Connector: SubConn MCBH6M

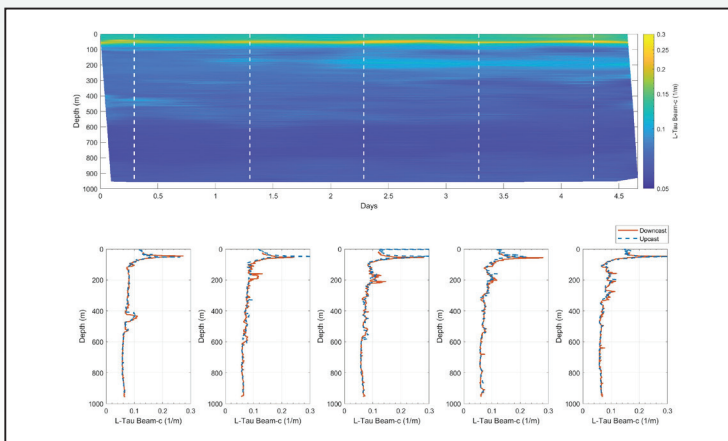

LISST-Tau data from 20+ profiles collected over a 4.5 day glider deployment. Dashed lines indicate timing of the five individual profiles. Note chlorophyll maximum, small-scale structure and stability over time and pressure.

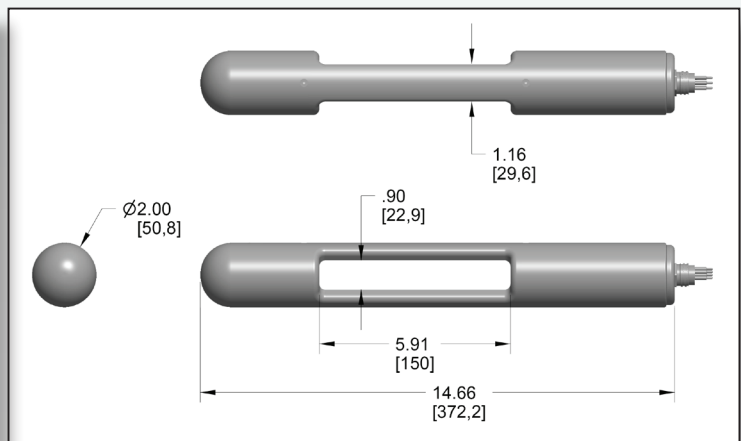

LISST-Tau Dimensions